



**FITTING INSTRUCTIONS FOR EH0096BK EXHAUST HANGAR
BMW R1250R + R1250RS SPORT 2019-**



THIS KIT CONTAINS THE ITEMS PICTURED AND LABELLED OVER PAGE.

SOME PARTS MAY BE SHOWN FOR CLARITY OF INSTRUCTIONS ONLY.

DO NOT PROCEED UNTIL YOU ARE SURE ALL PARTS ARE PRESENT.

PLEASE READ ALL INSTRUCTIONS BEFORE PROCEEDING.

**IF IN ANY DOUBT WHEN FITTING OUR PRODUCTS, CONSULT ONE OF OUR DEALERS OR HAVE
FITTED BY A QUALIFIED TECHNICIAN.**

PLEASE NOTE THAT THE WAY THE KIT IS PACKED DOES NOT NECESSARILY REPRESENT THE WAY OF
MOUNTING TO THE BIKE.

IN THE EVENT OF RUBBER WASHERS BEING USED TO HOLD COMPONENTS ONTO BOLTS,
THESE RUBBER WASHERS CAN BE THROWN AWAY.

DIGITAL COPIES OF THESE INSTRUCTIONS ARE AVAILABLE FROM:

WWW.RG-RACING.COM

R&G Racing

Unit 1, Shelleys Lane, East Worldham, Alton, Hampshire GU34 3AQ.

Tel: +44 (0)1420 89007 Fax +44 (0)1420 87301 www.rg-racing.com Email: info@rg-racing.com



| <u>TOOLS REQUIRED</u> | <u>GENERAL TORQUE SETTINGS</u> |
|---|--|
| <ul style="list-style-type: none"> TORX HEAD TOOLS (T-BAR OR SOCKETS) ALLEN HEAD TOOLS (T-BAR OR SOCKETS) | <p>M4 BOLT = 8Nm</p> <p>M5 BOLT = 12Nm</p> <p>M6 BOLT = 15Nm</p> <p>M8 BOLT = 20Nm</p> <p>M10 BOLT = 40Nm</p> <p>M12 BOLT = 40Nm</p> |

LEGEND

| ITEM No. | DESCRIPTION | QTY |
|----------|----------------------------|-----|
| ITEM 1 | HB0065 EXHAUST HANGER | 1 |
| ITEM 2 | M8 X 20MM BUTTON HEAD BOLT | 2 |
| ITEM 3 | M8 X 16MM BUTTON HEAD BOLT | 1 |
| ITEM 4 | M8 WASHER (19mm O/D) | 1 |

EXPLODED ASSEMBLY DIAGRAM

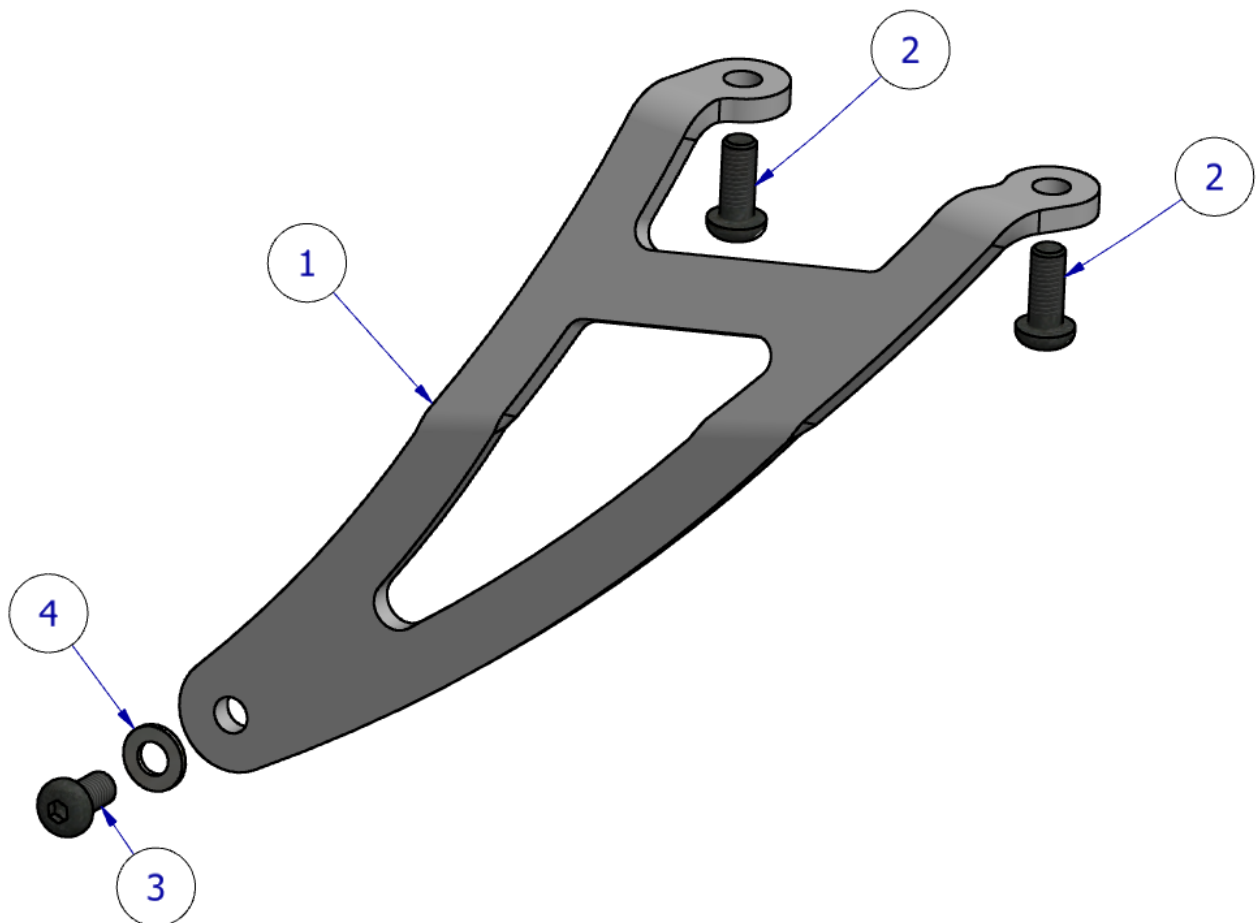

R&G Racing

Unit 1, Shelleys Lane, East Worldham, Alton, Hampshire GU34 3AQ.

Tel: +44 (0)1420 89007 Fax +44 (0)1420 87301 www.rg-racing.com Email: info@rg-racing.com



FITTING INSTRUCTIONS

- Remove the original OEM footrest + exhaust hanger on the RHS of the bike using your torx tool.
- Offer up your R&G exhaust hanger into position and place the two longer M8 button head bolts (item 2) through the two top holes.
- Engage the threads into the underside of the subframe but do not fully tighten.
- Place the washer (item 4) from the kit over the remaining shorter M8 button head bolt (item 3) and position through the exhaust hanger and tighten into the threads of the exhaust.
- Fully tighten the top two mount bolts to the correct torque.
- Ensure the exhaust hanger is correctly fitted and check tightness of all bolts before riding.

Please ensure when the motorcycle is being used that no parts are in such a position that they may collide/damage other bike parts (this is particularly important if using after-market cans or exhaust systems).

Please note that it is your responsibility to ensure that no part of the exhaust hanger or exhaust assembly fouls or comes into contact with other parts of the machine. Do not ride the motorcycle until this aspect has been verified and you have compressed the rear suspension (if appropriate to the design of the motorcycle) to test this thoroughly.

ISSUE 1 - 14/10/2019 (DM)

CONSUMER NOTICE

The catalogue description and any exhibition of samples are only broad indications of the Products and R&G may make design changes which do not diminish their performance or visual appeal and supplying them in such state shall conform to the order. The Buyer acknowledges no representation or warranty (other than as to title) has been given or will apply to the Products other than those in R&G's order or confirmation and the Buyer confirms it has chosen the Products as being of merchantable quality and suitable for its particular purposes. Where R&G fits the Products or undertakes other services it shall exercise reasonable skill and care and rectify any fault free of charge unless the workmanship has been disturbed. The Buyer is responsible for ensuring that the warranty on the motorcycle is not affected by the fitting of the Products. On return of any defective Products R&G shall at its option either supply a replacement or refund the purchase money but shall not be liable if the Products have been modified or used or maintained otherwise than in accordance with R&G's or manufacturer's instructions and good engineering practice or if the defect arises from accident or neglect. Other than identified above and subject to R&G not limiting its liability for causing death and personal injury, it shall not be liable for indirect or consequential loss and otherwise its liability shall be limited to the amounts paid by the Buyer for the Products or the fitting or service concerned. These terms do not affect the Buyer's statutory rights.

R&G RETURNS POLICY (NON-FAULTY GOODS)

Returns must be pre-authorized (if not pre-authorized the return will be rejected). Goods may only be returned direct to us if they were purchased direct from us (customer must prove if necessary). Otherwise to be returned to original vendor. Goods must be in re-sellable condition, in the opinion of R&G. All returns are subject to a 25% restocking and handling fee (25% of the gross value exc. P&P – at the prevailing price at time of purchase). The customer must pay any and all carriage charges. No returns of discontinued products, unless within 14 days of purchase. This policy does not affect your statutory rights and does not refer to faulty goods.

R&G Racing

Unit 1, Shelleys Lane, East Worldham, Alton, Hampshire GU34 3AQ.

Tel: +44 (0)1420 89007 Fax +44 (0)1420 87301 www.rg-racing.com Email: info@rg-racing.com



NOTICE DE MONTAGE POUR EH0096BK SUPPORT D'ÉCHAPPEMENT BMW R1250R + R1250RS SPORT 2019-



LE KIT CONTIENT LES ARTICLES EN PHOTO ET ÉTIQUETTES SUR LA PAGE

LES PARTIES PRÉSENTÉES PEUVENT ÊTRE UNIQUEMENT REPRESENTATIVES POUR LA CLARTE DES INSTRUCTIONS

NE PAS PROCÉDER AU MONTAGE AVANT DE VOUS ÊTRE ASSURÉ QUE TOUTES LES PIÈCES SOIENT PRÉSENTES.

SVP, LIRE L'ENSEMBLE DE LA NOTICE AVANT DE PROCÉDER AU MONTAGE.

EN CAS DE DOUTE LORS DU MONTAGE, CONSULTEZ UN DE NOS REVENDEURS, OU FAITES EFFECTUER LE MONTAGE PAR UN TECHNICIEN QUALIFIÉ.

LA FAÇON DONT LE KIT EST EMBALLÉ NE CORRESPOND PAS FORCÉMENT À LA FAÇON DE MONTER LES PIÈCES SUR LA MOTO .

NOTEZ QUE SI LES KITS SONT EMBALLÉS AVEC DES RONDELLES EN CAOUTCHOUC SERVANT À TENIR LES COMPOSANTS, CES RONDELLES DOIVENT ÊTRE JETÉES.

NOTICE DISPONIBLE AU TÉLÉCHARGEMENT SUR :

WWW.RG-RACING.COM

R&G Racing

Unit 1, Shelleys Lane, East Worldham, Alton, Hampshire GU34 3AQ.

Tel: +44 (0)1420 89007 Fax +44 (0)1420 87301 www.rg-racing.com Email: info@rg-racing.com



| OUTILS REQUIS | VALEURS DE SERRAGE |
|---|---|
| <ul style="list-style-type: none"> • OUTILS TORX (BARRE EN T OU CLE) • OUTILS ALLEN (BARRE EN T OU CLE) | M4 BOULON = 8Nm M5 BOULON = 12Nm M6 BOULON = 15Nm M8 BOULON = 20Nm M10 BOULON = 40Nm M12 BOULON = 40Nm |

LEGENDE

| ARTICLE | DESCRIPTION | QTE |
|----------------|------------------------------|------------|
| ARTICLE 1 | HB0065 SUPPORT D'ÉCHAPPEMENT | 1 |
| ARTICLE 2 | M8 X 20MM BOULON | 2 |
| ARTICLE 3 | M8 X 16MM BOULON | 1 |
| ARTICLE 4 | M8 RONDELLE (19mm O/D) | 1 |

SCHEMA DE MONTAGE

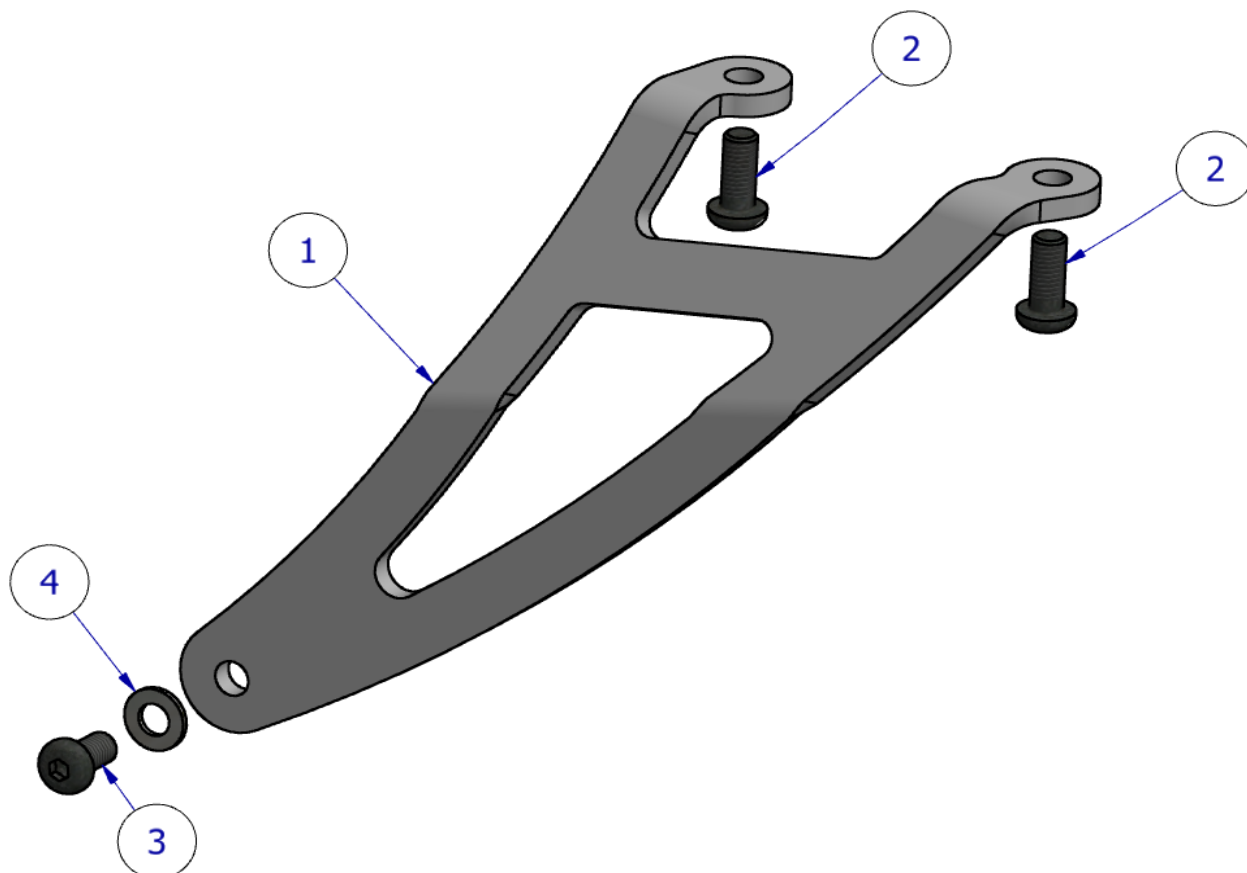

R&G Racing

Unit 1, Shelleys Lane, East Worldham, Alton, Hampshire GU34 3AQ.

Tel: +44 (0)1420 89007 Fax +44 (0)1420 87301 www.rg-racing.com Email: info@rg-racing.com



NOTICE DE MONTAGE

- Retirez le repose-pied d'origine + le support d'échappement du coté droit de la moto, à l'aide de votre outil Torx.
- Placez votre support d'échappement R&G en place et placez les deux boulons M8 (article 2) plus longs dans les deux trous supérieurs.
- Engagez les filets sur le dessous du sous-châssis mais ne serrez pas complètement.
- Placez la rondelle (article 4) du kit sur le dernier boulon à tête ronde M8 (article 3), positionnez-la à travers le support d'échappement et serrez-la dans le filetage de l'échappement.
- Serrez complètement les deux boulons de fixation supérieurs au couple correct.
- Assurez-vous que le support d'échappement soit correctement installé et vérifiez le serrage de tous les boulons avant de prendre la route.

Veillez vous assurer, lors de l'utilisation de la moto, qu'aucune pièce ne se trouve dans une position telle qu'elle puisse entrer en collision / endommager d'autres pièces de la moto (ceci est particulièrement important si vous utilisez un système d'échappement non d'origine).

Il est de votre responsabilité de veiller à ce qu'aucune partie du support de pot d'échappement ne puisse entrer en contact avec d'autres parties de la moto. Ne pas utiliser la moto tant que ce point n'a pas été vérifié, en ayant compressé l'amortisseur arrière (si le design de la moto le permet).

ISSUE 1 - 14/10/2019 (DM)

R&G Racing

Unit 1, Shelleys Lane, East Worldham, Alton, Hampshire GU34 3AQ.

Tel: +44 (0)1420 89007 Fax +44 (0)1420 87301 www.rg-racing.com Email: info@rg-racing.com



MONTAGEANLEITUNG FÜR EH0096BK AUSPUFFHALTERUNG BMW R1250R + R1250RS SPORT 2019-



ALLE KIT-TEILE SIND UNTEN ABGEBILDET UND GEKENNZEICHNET.

DIE ABGEBILDETEN TEILE DIENEN LEDIGLICH ZUR ERKLÄRUNG.

ÜBERPRÜFEN SIE ZUERST, DASS ALLE TEILE VORHANDEN SIND.

LESEN SIE DIE MONTAGEANLEITUNG KOMPLETT DURCH, BEVOR SIE ANFANGEN. WENN SIE BEI DER MONTAGE DIESES PRODUKTES UNSICHER SIND, BITTE EINEN UNSERER HÄNDLER KONTAKTIEREN ODER DAS KIT VON EINEM QUALIFIZIERTEN

DIE VERPACKUNG DER TEILE STELLT NICHT DIE REIHENFOLGE DER MONTAGE DAR.

HINWEIS FÜR KITS MIT PLASTIKUNTERLEGSCHLEIBEN AN DEN SCHRAUBEN –
DIESE PLASTIK-UNTERLEGSCHLEIBEN WERDEN NICHT FÜR DEN EINBAU BENÖTIGT

EINE DIGITALE VERSION DIESER MONTAGEANLEITUNG KANN AUF FOLGENDER SEITE HERUNTERGELADEN WERDEN: [WWW.RG-RACING.COM](http://www.rg-racing.com)

R&G Racing

Unit 1, Shelleys Lane, East Worldham, Alton, Hampshire GU34 3AQ.

Tel: +44 (0)1420 89007 Fax +44 (0)1420 87301 www.rg-racing.com Email: info@rg-racing.com

**SIE BENÖTIGEN FOLGENDES WERKZEUG**

- Satz Torx-Schlüssel
- Satz Inbusschlüssel

ALLEM. ANZUGSDREHMOMENT

M4 SCHRAUBE = 8Nm
 M5 SCHRAUBE = 12Nm
 M6 SCHRAUBE = 15Nm
 M8 SCHRAUBE = 20Nm
 M10 SCHRAUBE = 40Nm
 M12 SCHRAUBE = 40Nm

LIEFERUMFANG

| ARTIKEL-NR. | BESCHREIBUNG | MENGE |
|-------------|-------------------------------|-------|
| ARTIKEL 1 | HB0065 AUSPUFFHALTERUNG | 1 |
| ARTIKEL 2 | M8 X 20MM INBUSSCHRAUBE | 2 |
| ARTIKEL 3 | M8 X 16MM INBUSSCHRAUBE | 1 |
| ARTIKEL 4 | M8 UNTERLEGSCHIEBE (19mm O/D) | 1 |

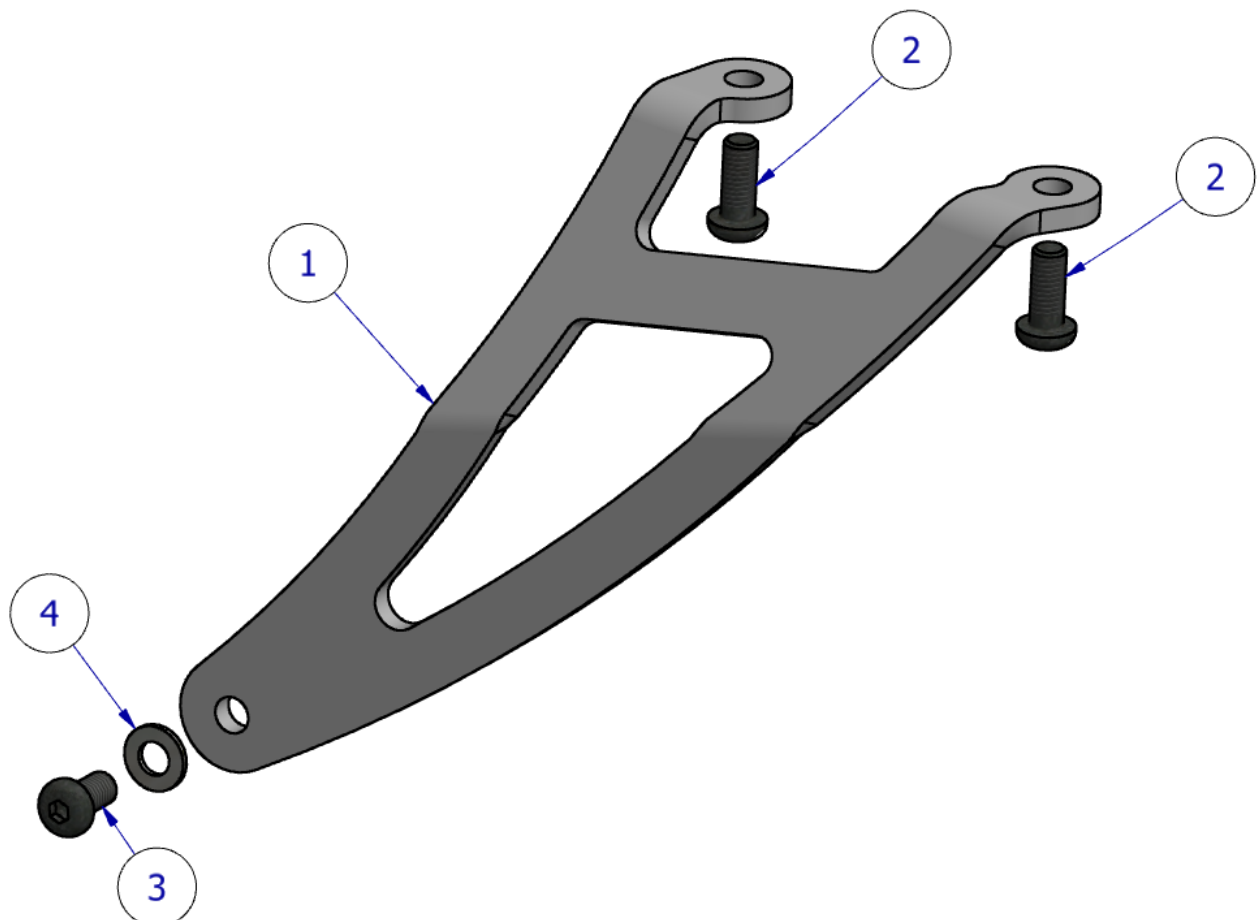
EXPLOSIONSZEICHNUNG—ZUSAMMENBAU

R&G Racing

Unit 1, Shelleys Lane, East Worldham, Alton, Hampshire GU34 3AQ.

Tel: +44 (0)1420 89007 Fax +44 (0)1420 87301 www.rg-racing.com Email: info@rg-racing.com



MONTAGEANLEITUNG

- Entfernen Sie die original Fußraste und Auspuffhalterung an der rechten Seite des Motorrades mit dem Torx-Schlüssel.
- Die R&G Auspuffhalterung in Position bringen und die zwei längere M8 Inbusschrauben (Artikel 2) in die zwei oberen Öffnungen einsetzen.
- Die Gewinde an der Unterseite des Hilfsrahmens einsetzen aber nicht komplett festziehen.
- Eine Unterlegscheibe vom Kit (Artikel 4) an der übrigen, kürzeren M8 Inbusschraube (Artikel 3) anbringen. Die Schraube dann durch die Auspuffhalterung in die Gewinde am Auspuff eindrehen und festziehen.
- Ziehen Sie die oberen zwei Montageschrauben mit dem richtig Anzugsdrehmoment fest.
- Überprüfen Sie, dass die Auspuffhalterung ordnungsgemäß montiert ist und kontrollieren Sie, dass alle Schrauben festgezogen sind, bevor Sie mit dem Motorrad fahren.
-

Bitte achten Sie darauf, dass keine Teile so angebaut werden, dass sie andere Teile des Motorrades beschädigen/berühren können (die ist besonders wichtig, wenn Sie einen Auspuff oder Endtopf aus dem Zubehörmarkt anbauen).

Wichtiger Hinweis: Es obliegt Ihrer Verantwortung sicherzustellen, dass keine Teile der Auspuffhalterung oder Auspuffanlage mit anderen Teilen des Motorrades in Berührung kommen und/oder sie beschädigen. Fahren Sie nicht mit dem Motorrad bis dies sorgfältig überprüft wurde und Sie den hinteren Federweg genau kontrolliert haben (falls zutreffend, Modellabhängig).

AUSGABE 1 - 14/10/2019 (DM)

R&G Racing

Unit 1, Shelleys Lane, East Worldham, Alton, Hampshire GU34 3AQ.

Tel: +44 (0)1420 89007 Fax +44 (0)1420 87301 www.rg-racing.com Email: info@rg-racing.com